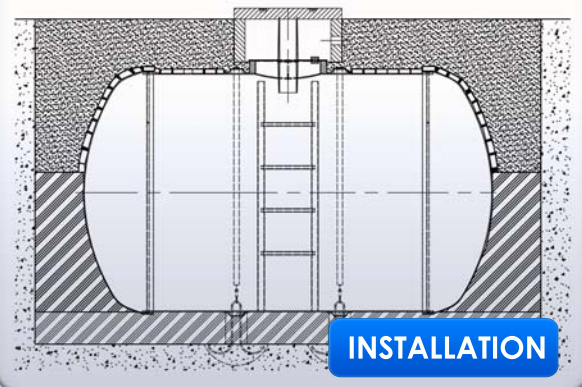
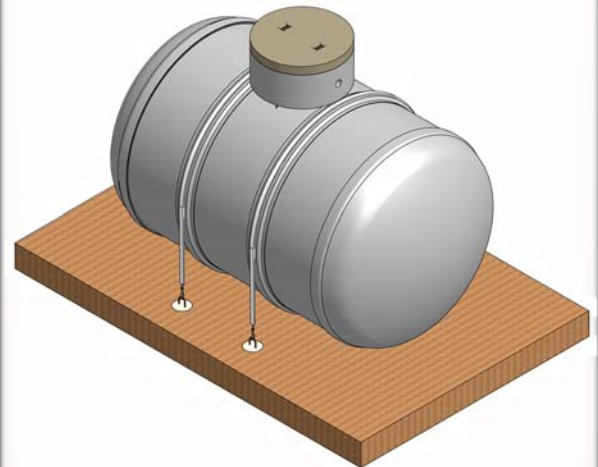

- 'COMPTNK' - a factory moulded Composite Underground Treated water Storage Tank of 13,500 litre capacity; It can be installed in a day & effectively used on the same day.
- COMPTNK is made from homogeneous composite which is impervious to water seepage; it never allows leakage of water from tank to soil or ingress of moisture from soil.
- COMPTNK has standard dimensions in diameter, length and wall thickness. All tanks are tested for pressure by hydro-testing and overall quality is ensured as per BS 4994 standards.
- COMPTNK is having glassy finishing on its inside; hence growth of algae and other type of bio-fouling considerably eliminated. Since the tank is totally sealed there is no evaporation.
- COMPTNK does not corrode even in saline conditions since it is not constructed using steel reinforcements like RCC tanks.
- COMPTNK is competitive than RCC tank when we compare its cost. It is specially designed for a minimum life of 75 Years.
- COMPTNK occupies only 5% more space than the water volume stored. This aspect is very crucial in cities having acute space restriction problem.
- COMPTNK can be used as overhead tank, since it is light weight and is not affected by sun's UV rays.
- COMPTNK can be supplied with inside partitions & with any number of nozzles to meet the specific needs of the clients.
- COMPTNK can be transported by commercial vehicle as its dimensions are 2.3 M dia. x 3.9 M long.
- COMPTNK can be shifted from one place to other, even after the usage during modification or renovations of building.

**Tank Capacity: 13,500 Litres**  
COMPTNK can be installed in a day & effectively used on the same day.

**COMPTNK****INSTALLATION**